

USER MANUAL

Project Number: GPHB-48100S



(-2/-3/-4/-5/-6/-7/-8)

High Voltage Battery System



本文档描述了安装、电气连接、操作、调试、高压电池系统的维护和故障排除。在安装以及操作高压电池系统之前，确保您熟悉本文档提供的产品特性、功能和安全注意事项。

This document describes the installation, electrical connection, operation, commission, maintenance and troubleshooting of High Voltage Battery System. Before installing and operating High Voltage Battery System, ensure that you are familiar with product features, functions, and safety precautions provided in this document.

符号 Symbol	描述 Description
 WARNING	表示如果不可避免，可能会导致潜在的危险情况，例如严重受伤或死亡。 Indicates a potentially hazardous situation, if not avoided, could result in serious injury or death.
 Notice	表示如果不注意，可能会导致操作或使用过程中的困难。 Indicates may have problem in operation or use, if do not pay attention to it.

目录 Contents

1、产品概述 Product Overview	1
1.1 预期用途 Intended Use	1
1.2 外观 Appearance.....	1
1.2.1 GPHB-48100S.....	1
1.2.2 GPHB-48100S Module.....	3
1.3 工作原理及功能 Working Principle and Function	5
2、安全性 Safety	5
2.1 基本安全保障 Basic security	6
2.2 安全措施 Safety Precautions	7
2.2.1 环境要求 Environment requirements	7
2.2.2 操作注意事项 Operation Precautions.....	7
2.3 警告标签 Warning Labels.....	8
2.4 应急处理 Emergency Responses.....	11
3、储存和运输 Storage and Transportation	12
3.1 存储要求 Storage Requirements	12
3.2 运输要求 Transportation Requirements	13
4、安装 Installation	13
4.1 基本安装要求 Basic Installation Requirements	15
4.2 安装工具 Installation Required Tools	16
4.3 安装步骤 Installation Procedures.....	17
4.3.1 安装前检查 Pre-installation Check.....	17
4.3.2 落地式安装 Floor Standing Installation.....	18
4.4 电气连接 Electrical Connection	19
4.4.1 RJ45通讯端口针脚定义	19
Definition of RJ45 communication port pin	
4.4.2 系统连线图 System connection diagram.....	20
5、开关电池系统 Power on/off Battery system	21
5.1 电池系统开机 Power on Battery system	21
5.2 电池系统关机 Power off Battery system	22
6、维护指南 Maintenance Guidelines	23
6.1 准备工作 Preparation	23
6.2 更换电池组或高压控制器	23
Battery pack or high voltage controller replacement	
6.3 系统故障信息及建议	24
System fault information and suggestions	
7、技术规格 Technical Specifications	26
7.1 系统数据 System Data	26
7.2 高压控制器 High voltage controller	29
7.3 电池组 Battery pack	29
附录 Appendix	31

1、产品概述 Product Overview

1.1 预期用途 Intended Use

整个GPHB-48100S高压电池系统包括一个GPHB-48100S(高压控制器)和多个GPHB-48100S Module(电池组)。每一个GPHB-48100S Module包含一个由100Ah电芯通过1并和16串连接(1P16S)组成电压为51.2V的电池组。可串联连接2到8个GPHB-48100S Module扩展储能系统的容量和功率。GPHB-48100S电池系统在夜间没有太阳能的情况下可通过PCS给负载供电;当白天太阳能可用时,太阳能将优先给负载供电并将剩余的太阳能存入GPHB-48100S电池系统。

The entire GPHB-48100S High Voltage Battery System includes a GPHB-48100S (high voltage controller) and multiple GPHB-48100S Module (battery pack). Each GPHB-48100S Module consists of 100Ah cells which form 51.2V voltage battery pack via one parallel and sixteen serial connection (1P16S). Two to eight GPHB-48100S Module can be connected in serial to extend the capacity and power of energy storage system. The GPHB-48100S battery system powers the loads through PCS at nighttime without solar; when solar becomes available during daytime, solar energy powers the loads as a priority and store residual solar power into the GPHB-48100S battery system.

1.2 外观 Appearance

1.2.1 GPHB-48100S

高压控制器由电池控制单元、直流断路器、供电电源、电源端子及通讯端子构成。产品外观如下图。

The high voltage controller is composed of battery control unit, DC breaker, power supply and communication terminals. The appearance of the product is shown as below.

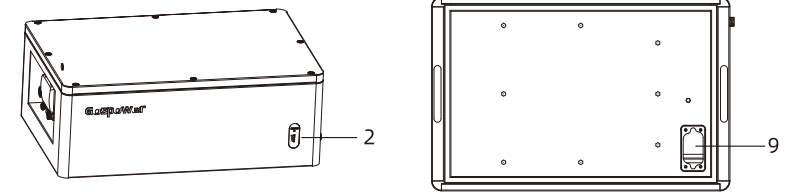
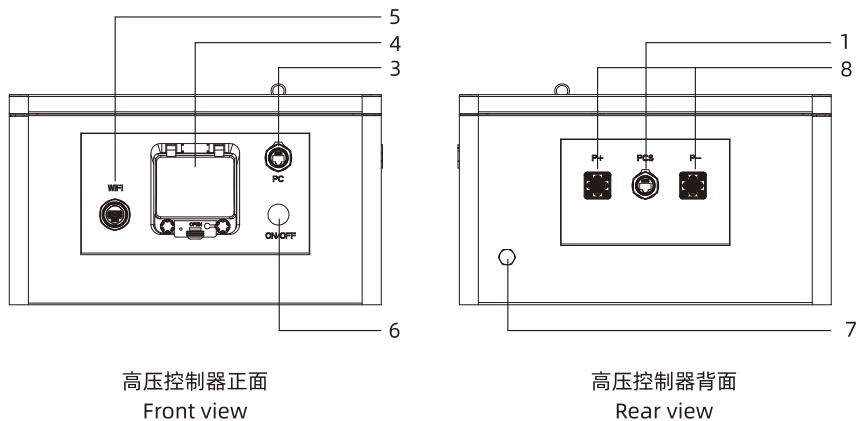

位号 Number	端口 Port	功能 Function
1	PCS	电池系统到PCS输出及与PCS通讯 The output from battery system to the PCS and communication with PCS
2	LED	SOC及系统工作状态指示 SOC and working status indication of the system
3	PC	与PC通讯 Communication with PC
4	Breaker	打开、关闭整个电池系统的断路器 Breaker to turn on/off the whole battery system
5	WiFi	与无线模块通讯 Communication with WiFi Dongle
6	Power button	唤醒电池系统 Wake up the battery system
7	Pressure relief valve	泄放内部压力 Pressures inside is released via the valve
8	P+/P-	电池输入输出的正负极 The positive and negative electrodes of the battery pack input and output
9	Module	连接电池组 Connect to battery pack

尺寸 (单位: mm)
Dimension (unit: mm)

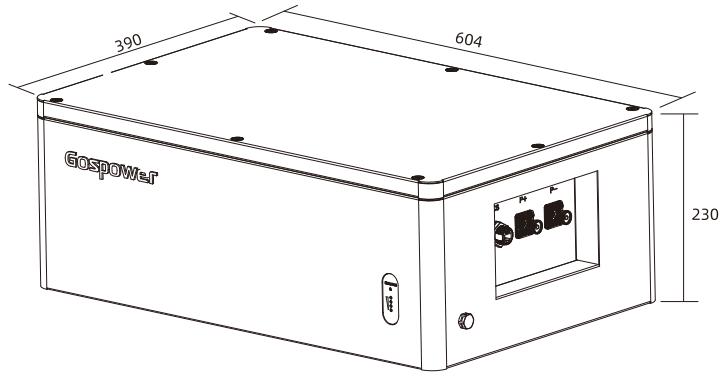

GPHB-48100S

1.2.2 GPHB-48100S Module

GPHB-48100S Module 由电池模块 (包括电芯及机械部件)、电池管理单元 (BMU)、电源端子和通讯端子构成。产品外观如下图。

GPHB-48100S Module consist of battery module (including cell and mechanical parts), Battery management unit (BMU) as well as power and communication terminals. Product appearance is shown as below.

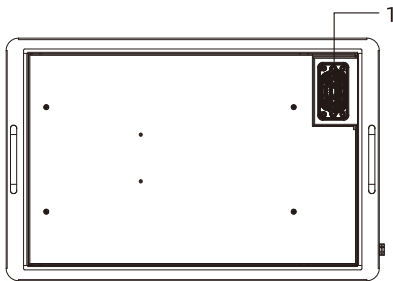

电池箱顶面
Top view

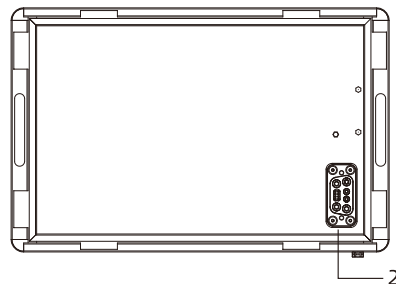

电池箱底面
Bottom view

位号 Number	端口 Port	功能 Function
1	上行端口	连接高压控制器或电池组 Connect to high voltage controller or battery pack
2	下行端口	连接电池组或底座 Connect to battery pack or pedestal

尺寸 (单位: mm)
Dimension (unit: mm)

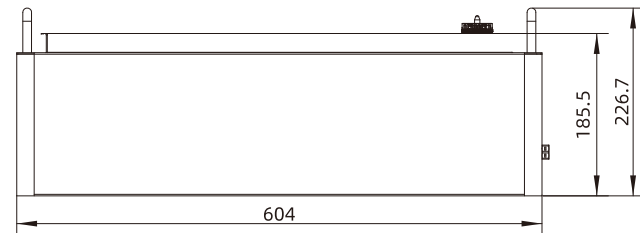
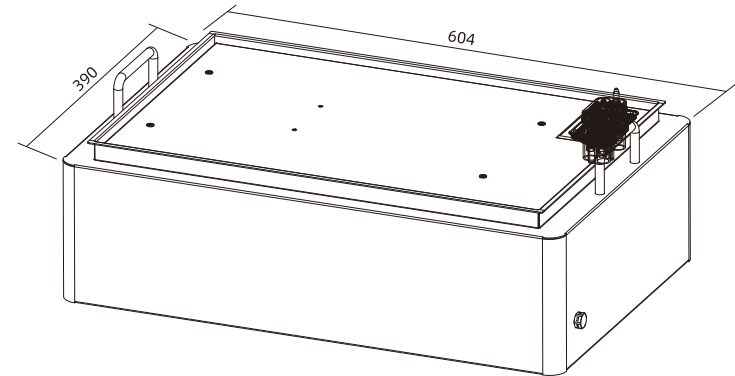

GPHB-48100S Module

1.3 工作原理及功能 Working Principle and Function

GPHB-48100S高压电池系统由高压控制器GPHB-48100S和电池组GPHB-48100S Module串联组成。它包括电化学电池、电池控制单元、电池管理单元、电源和信号端子以及机械部件。

The GPHB-48100S high voltage battery system is composed of a high voltage controller GPHB-48100S and battery pack GPHB-48100S Module in series. It contains electrochemical batteries, battery control units, battery management units, power and signal terminals, and mechanical parts.

与其他电池系统相比，具有更好的充放电性能、更高的充放电效率、更准确的状态监测、更长的循环寿命和更少的自放电损耗。

Compared with other battery systems, it has better charging and discharging performance, higher charging and discharging efficiency, more accurate status monitor, longer cycle life and less self-discharge loss.

单套系统可串联2到8个电池组，以增加电池系统的容量和功率。整个电池系统通过CAN通信与逆变器通信，运行稳定性高。

A single cluster system can connect 2 to 8 packs in series to increase the capacity and power of the battery system. The entire battery system communicates with the inverter through CAN communication, and the operation stability is high.

- ◆ 监控：分别对电芯和整个电池系统的电压、电流及温度进行监测。
- ◆ 保护及告警：过压、欠压、过电流、高温、低温保护及告警。详见附录一。
- ◆ 报告：向PCS和PC报告所有状态数据。
- ◆ 串联：支持2到8个电池组串联连接。
- ◆ 故障断电：欠压保护后30分钟或电池静置3天。
- Monitoring: voltage, current and temperature detection of both single cells and battery system.
- Protection and Alarm: protection and alarm when over voltage, under voltage, over current, over temperature or under temperature occurs. See Appendix I for the details.
- Report: report all alarm and status data to PCS.
- Series connection: support two to eight packs in Series connection.
- Power failure triggered by fault: 30 minutes after under voltage protection or battery rest for 3 days.

2、安全性 Safety

当安装或使用电池系统时，必须始终遵守本节中包含的安全信息。出于安全原因，安装人员有责任在安装前熟悉本手册和所有告警。

When installing or using a battery system, the safety information contained in this section must always be followed. For safety reasons, it is the installer's responsibility to be familiar with this manual and all warnings before installation.

2.1 基本安全保障 Basic security

电池系统经过严格的设计和测试，符合国际安全认证要求。在安装或使用电池系统之前，请仔细阅读所有安全说明，并始终遵循相关规则。高斯宝不负责因违反以下规定而产生的任何后果：

The battery system has been designed and tested in accordance with strict rules with international safety certification requirements. Before any installation or use of the battery system, please read all safety instructions carefully and always follow the relevant rules. Gospower is not responsible for any consequences resulting from violation of the following regulations:

- ◆ 运输过程中发生的损坏。
- ◆ 运输、储存、安装、使用不正确，或客户未向终端客户传达正确的运输、储存、安装、使用信息。
- ◆ 非专业安装。
- ◆ 不遵守本操作说明和本文档中的安全注意事项。
- ◆ 使用未经授权修改或删除的软件包。
- ◆ 防拆标签损坏或产品缺少任何部件(授权可拆卸部件除外)。
- ◆ 本文档所述操作不允许在极端环境下进行。
- ◆ 因未经授权的修理、拆卸或更换包装造成的故障。
- ◆ 外壳标签损坏或修改生产日期。
- ◆ 超过6个月未充电的电池包。
- ◆ 因不可抗力(如闪电、地震、火灾、风暴等)造成的损坏。
- ◆ 超过保修期。
- Damage occurred during transportation.
- Incorrect transportation, storage, installation and use, or customer fails to convey the correct information about transportation, storage, installation and use to terminal customers.
- Non-professional installation.
- Failure to obey the rules of this operation instructions and safety precautions in this document.
- Unauthorized modifications or removal of the software package.
- The product's tamper label is damaged or the product lacks any parts (except authorized disassembly parts).
- Operation in extreme environments which are not allowed in this document .
- Repair, disassemble, or change packs without authorization and cause failure.
- Damage to shell labels or modifies date of production.
- Packs fail to be charge for more than six months.
- Damages due to force majeure (such as lightning, earthquakes, fire, and storms).
- Warranty expiration.

2.2 安全措施 Safety Precautions

2.2.1 环境要求 Environment requirements







- ◆ 请勿将电池暴露在45°C以上的环境或热源中。
- ◆ 不要在潮湿、潮湿、腐蚀性气体或液体中安装或使用电池，如浴室。
- ◆ 不要将电池长时间暴露在阳光下。
- ◆ 把电池放在远离儿童和动物的地方。
- ◆ 电池电源端子不得接触电线等导电物体。
- ◆ 请勿将电池置于火中，否则可能引起爆炸。
- ◆ 电池系统不得与液体接触。
- Do not expose the battery to temperature above 45°C or heat sources.
- Do not install or use the battery in wet locations, moisture, corrosive gases or liquids, such as bathroom.
- Do not expose the battery to direct sunlight for extended periods of time.
- Place battery in safe place away from children and animals.
- Battery power terminals shall not touch conductive objects such as wires.
- Do not dispose the batteries in fire, which may cause an explosion.
- The battery system shall not come in contact with liquids.





2.2.2 操作注意事项 Operation Precautions

- ◆ 请勿用湿手触摸电池系统。
- ◆ 禁止自行拆卸电池系统。
- ◆ 不要压碎、掉落或刺穿电池组和高压控制器。
- ◆ 请按照当地安全法规回收处理电池。
- ◆ 电池储存和充电应符合本手册规定。
- ◆ 确保接地线连接可靠。
- ◆ 在安装、更换和维修前，请取下所有可能导致短路的金属物体，如手表和戒指。
- ◆ 电池组应由得到认可的技术人员修理、更换或维护。
- ◆ 在储存或搬运电池时，请勿将电池在无包装的情况下堆叠。
- ◆ 不要打破电池，释放的电解液可能有毒，对皮肤和眼睛有害。
- ◆ 已包装的电池堆放的数量不得超过包装箱上规定的数量。
- ◆ 请勿使用损坏、失效或变形的电池，否则可能导致高温甚至发生危险事故。损坏的电池继续运行可能会导致触电、火灾甚至更糟。
- Do not touch the battery system with wet hands.
- Do not disassemble the battery system without permission.
- Do not crush, drop or pierce the battery pack and high voltage controller.
- Dispose the batteries according to local safety regulations.
- Store and recharge battery in accordance with this manual.
- Ensure the connection of ground wire reliable.

- Remove all metal objects such as watches and rings that could cause a short-circuit before installation, replacement and maintenance.
- The pack shall be repaired, replaced or maintained by skilled personal that has been recognized.
- When storing or handling batteries ,do not stack batteries without package.
- Do not broke the battery, the released electrolyte may be toxic and is harmful to skin and eyes.
- Packaged batteries should not be stacked more than specified number stipulated on the packing case.
- Do not use damaged, failed or deformed batteries, which may lead to high temperature or even dangerous accidents. Continued operation of damaged battery may result in electrical shock, fire or even worse.

2.3 警告标签 Warning Labels

标志 Symbols	描述 Description
	不要丢弃在垃圾里 Do not dispose in trash
	锂离子电池可以回收利用 Lithium ion battery can be recycled
	欧盟地区的认证 Certification in European union area
	触电危险 Electric shock hazard
	易燃气体 Explosive gas
	可能泄漏腐蚀性电解质 May leak corrosive electrolyte
	重到足以造成严重伤害 Heavy enough to cause severe injury

	放置在远离儿童的地方 Keep the Pack away from children
	确保电池极性连接良好 Make sure the battery polarity well connected
	不要暴露在火中 Do not expose to fire
	按说明书操作 Operate as the Manual

主控箱铭牌展示图 Main control box nameplate display diagram

Gospower Rechargeable Li-ion Battery System





Model No./Nominal Voltage/Rated Energy

- GPHB-48100S-2 Module/102.4Vdc/10.24KWh
- GPHB-48100S-3 Module/153.6Vdc/15.36 KWh
- GPHB-48100S-4 Module/204.8Vdc/20.48KWh
- GPHB-48100S-5 Module/256Vdc/25.6KWh
- GPHB-48100S-6 Module/307.2Vdc/30.72 KWh
- GPHB-48100S-7 Module/358.4Vdc/35.84KWh
- GPHB-48100S-8 Module/409.6Vdc/40.96KWh

Max. Continuous Current: 75A
Rated Charge/Discharge Current: 50A
Battery Type: LiFePO4
Rated Capacity: 100Ah
Operating temperature: 0°C~60°C(Charge)
 -20°C~60°C(Discharge)

Protection Class: I
IP Class: IP65
Battery designation:
 IFpP51/161/120/[(1P16S)2S]M/-20+60/90

SN:





电池箱铭牌展示图 Battery box nameplate display

Rechargeable Li-ion Battery System Module

Model: GPHB-48100S Module
Nominal: 51.2Vdc
Voltage Range: 43.2~58.4Vdc
Max. Continuous Current: 50A
Battery Type: LiFePO4
Rated Energy: 5.12KWh
Rated Capacity: 100Ah
Operating Temperature: 0°C~45°C(Charge)
 -20°C~45°C(Discharge)

Protection Class: I
IP Class: IP65

SN:



Notice

当温度低于0°C时，性能将受到限制。
 The performance will be limited when the temperature is below 0°C.

2.4 应急处理 Emergency Responses

制造商考虑了可预见的风险场景，旨在减少危险和危险。但如果出现下列情况，请按如下步骤操作：

Manufacturer takes foreseeable risk scenarios into consideration and is designed to reduce hazards and dangers. However, if the following situation occurs, do as below:

发生情况 Situation Occurs	描述和需要采取的行动 Description and action need
泄漏 Leakage	<p>避免接触泄漏的液体或气体。如果接触到泄漏的电解液，请立即按以下步骤操作；</p> <p>吸入:疏散污染区域，并寻求医疗帮助；</p> <p>眼睛接触:用清水冲洗眼睛15分钟，并寻求医疗帮助；</p> <p>皮肤接触:用肥皂和清水彻底冲洗接触部位，并寻求医疗帮助；</p> <p>吞食:呕吐，并寻求医疗帮助。</p> <p>Avoid touch of leaking liquid or gas. If you touch the leaking electrolyte, do as below immediately.</p> <p>Inhalation: Evacuate the contaminated area, and seek medical help.</p> <p>Eye contact: Rinse eyes with flowing water for 15 minutes, and seek medical help.</p> <p>Skin contact: Rinse contacted area thoroughly with soap and water, and seek medical help.</p> <p>Ingestion: Vomiting, and seek medical help.</p>
起火 On fire	<p>电池系统很难自燃。如果电池着火，不要试图灭火，而是立即疏散人员。</p> <p>It's hard for battery system ignite spontaneously. If the battery has caught a fire, do not try to extinguish the fire but evacuate people immediately.</p>
湿包 Wet Packs	<p>如果电池系统浸泡在水中，请不要接触电池系统。立即联系高斯宝或经销商寻求技术援助。</p> <p>If the battery system is soaked or submerged in water, do not access it. Contact Gospower or distributors immediately for technical assistance.</p>
外壳受损 Damaged shell	<p>外壳的损坏是非常危险的，所以必须特别注意。它们不再适合使用，可能对人员有危险。如果电池盒损坏，请停止使用，并联系销售人员或者当地经销商。</p> <p>Damage to the shell is very dangerous, so special attention must be paid. They are no longer suitable for use and may be dangerous to personnel. If the battery case is damaged, please stop using it and contact seller or local distributor.</p>

3、储存和运输 Storage and Transportation

3.1 存储要求 Storage Requirements

储存时请按照包装上的标识放置产品。

请勿将产品倒置或侧放。

不良品需要与其他产品分开。

如果电池贮存时间超过六个月，应每六个月使用充电器对电池组进行一次充电，使电池组的SOC达到50%。

Place the product follow the identification on the packing case during storage.

Do not put the product upside down or sidelong.

The defective product needs to be separated from other product.

If the battery is stored for more than six months, the battery pack shall be recharged to 50% SOC every six months using a charger.

存储环境要求如下：

The storage environment requirements are as follows:

将产品放置在干燥、清洁、通风良好的地方。

存储时间小于一周(7天)的储存温度在-30°C至50°C之间。

如果产品需要长期存放超过6个月，存储温度应在-20°C~ 45°C之间，相对湿度应在5%~95%RH之间。

将产品放置远离腐蚀性和有机物质(包括气体暴露)。

不直接暴露在阳光和雨水下。

距离热源(如散热器)至少2米。

不暴露于强烈的红外线辐射。

Place the product in a dry, clean and well ventilated place.

The storage temperature for a short week (7 days) is between -30°C to 50°C.

If you store the product over a long period of six months, the storage temperature is between -20°C to 45°C, relative humidity: 5%~95%RH.

Place the product away from corrosive and organic substances (including gas exposure).

Free from direct exposure to sunlight and rain.

At least two meters away from heat sources (such as a radiator) .

Free from exposure to intensive infrared radiation.

 Notice	<p>如果不按照以上说明进行长期储存，会降低电池的循环寿命甚至损坏。</p> <p>If not follow the above instructions for long-term storage, the battery cycle life will be reduced or even damaged.</p>
---	---

3.2 运输要求 Transportation Requirements

电池组已在UN38.3(《危险货物运输建议:试验和标准手册》第六修订版第38.3节)和SN/T 0370.2-2009(第2部分:出口危险货物包装检验规则的性能试验)中获得认证。电池组属于第9类危险品。

Battery pack has been certified in UN38.3 (Section 38.3 of the sixth Revised Edition of the Recommendations on the Transport of Dangerous Goods: Manual of Tests and Criteria) and SN/T 0370.2-2009 (Part 2: Performance Test of the Rules for the Inspection of Packaging for Exporting Dangerous Goods). Battery pack is classified as category 9 dangerous goods.

电池组不得与其他易燃、易爆或有毒物质一起运输。

确保原始包装和标签完整和可识别。

防止阳光直接照射、雨水、温差造成的冷凝水和机械损伤。

禁止堆放超过6个电池组。

在运输和储存期间, 电池电量将会下降。

运输温度-20°C~ 45°C, 相对湿度:5%~95%RH。

The battery pack shall not be transported with other inflammable, explosive or toxic substances.

Ensure the original Package and label complete and recognizable.

Prohibit direct exposure to sunlight, rain, condensing water caused by temperature difference and mechanical damages.

Prohibit to pile up more than six battery pack.

There will be a drop in capacity during transportation and storage.

Transportation temperature is between -20°C to 45°C, relative humidity: 5%~95%RH.

4、安装 Installation

 WARNING	<p>电池的安装和使用需要很多专业知识。因此, 请确保技术人员在操作前已取得相关技术证书。</p> <p>为了解产品信息和安全注意事项, 请在安装前仔细阅读使用说明。</p> <p>操作人员应是经过良好培训的技术人员, 充分了解整个光伏系统、电网、电池系统、工作原理和国家区域标准。</p> <p>安装人员必须使用绝缘工具和佩戴安全设备。</p> <p>不按本指南规定的储存、运输、安装和使用要求造成的设备损坏不包括在保修范围内</p> <p>不要在易燃易爆物品附近安装或使用电池。</p> <p>电池应在-10°C~ 45°C通风良好的环境中使用。</p> <p>尽量减少环境中的灰尘和污垢。</p> <p>不要在浴室等高度潮湿的地方安装电池。</p> <p>请确保所有串联的电池组来自同一批次、同一型号、同一厂家。不要将旧电池与新电池混合使用。不超过200次循环的电池组被定义为新电池。</p>
--	---

 Notice	<p>The installation and use of batteries involve a lot of expertise. Therefore, please ensure that technicians have obtained relevant technical certificates before operation.</p> <p>Ensure to read the Guidance before installation in order to understand product information and safety cautions.</p> <p>Operators should be well trained technicians and fully understand the whole photovoltaic system, grid network, battery system, working principle and national regional standards.</p> <p>Installers must use insulating tools and wear safety equipment.</p> <p>Device damages caused by failure to comply with storage, transportation, installation and use requirements specified in Guidance are not covered by Warranty.</p> <p>Do not install or use battery near explosive or inflammable substances.</p> <p>Use battery in well-ventilated environment with temperature ranging from -10°C to 45°C.</p> <p>Maintain a minimum level of dust and dirt in the environment.</p> <p>Do not install battery in highly humid area such as bathroom.</p> <p>Please make sure that all battery pack connected in series are from the same batch, the same model and the same manufacturer. Do not mix old batteries with new batteries. A battery pack that does not exceed 200 cycles is defined as a new battery.</p>
 Notice	<p>在串联安装前, 请确保电池组的电压差不大于0.5V。</p> <p>安装电池时, 我们建议同一系统电池的生产日期应在3个月以内。</p> <p>Before installing in series, make sure that the voltage difference of the battery pack must be less than or equal to 0.5V.</p> <p>When installing the batteries, we recommend that the manufacturing date of batteries in the same system should be within 3 months.</p>

4.1 基本安装要求 Basic Installation Requirements

电池系统可安装在室内或室外。允许下列条件:

The battery system can be installed indoors or outdoors. The following conditions are allowed:

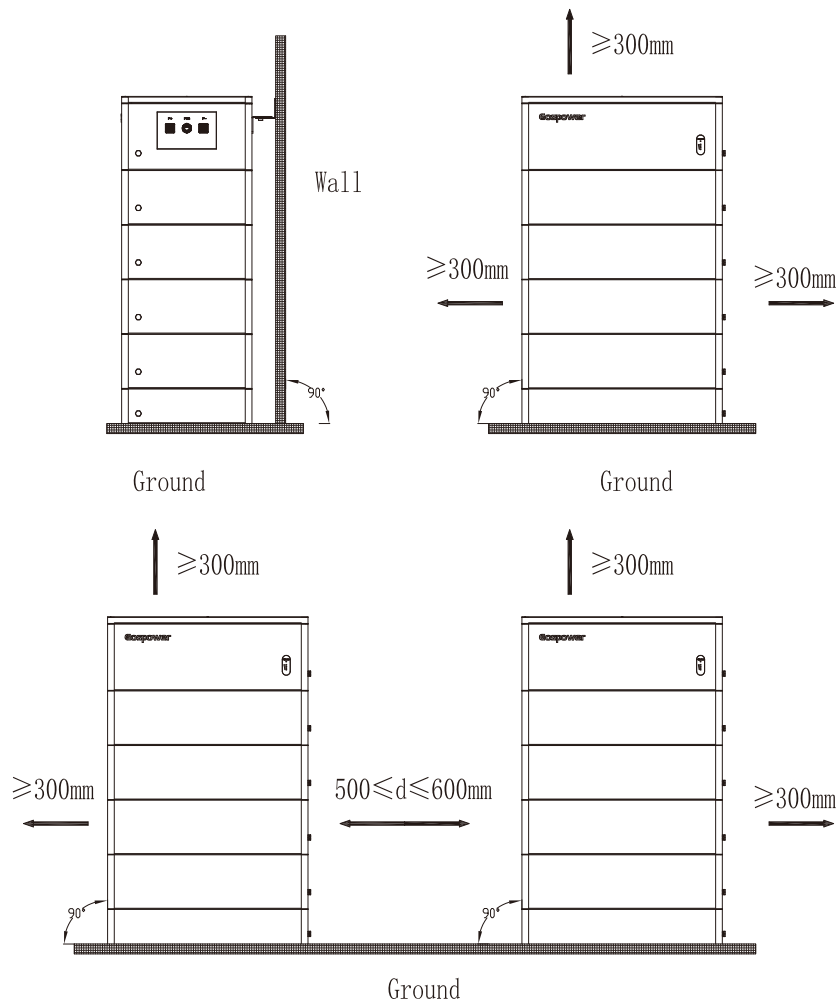

 WARNING	请勿将电池组倒置。 Do not place the battery pack upside down.
--------------------	---

在室外安装时，要安装遮阳板和避雨亭，避免直接暴露在阳光和雨水下。

When installing outdoors, it is necessary to install sunshades and rain shelters to avoid direct exposure to sunlight and rain.

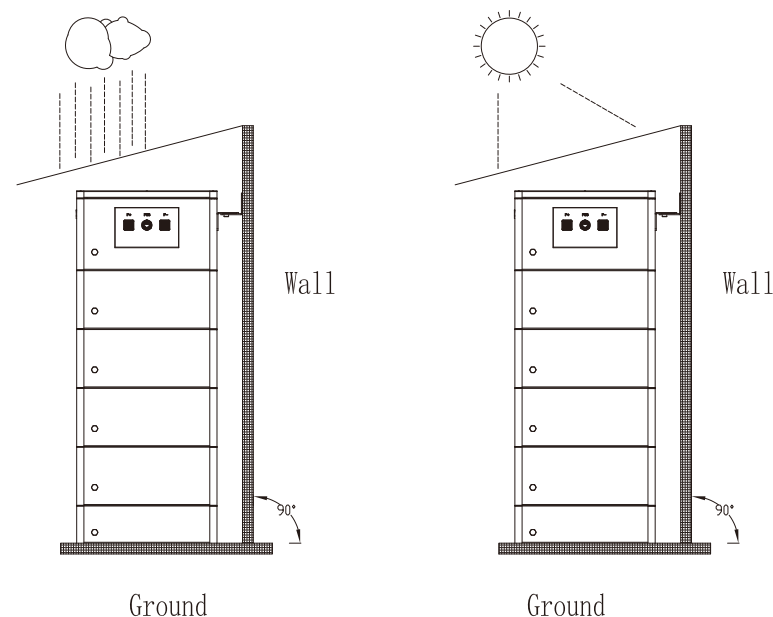

4.2 安装工具 Installation Required Tools

安装电池系统时，需要准备的工具如下:

The following tools are required to install the battery system:

 电钻 Electric drill	 螺丝刀 Screw Driver	 扳手 Wrench
 铅笔 Pencil	 卷尺 Tap Measure	 万用表 Multimeter

在处理电池系统时，建议佩戴以下安全装备。

It is recommended to wear the following safety gear when dealing with the battery system.



4.3 安装步骤 Installation Procedures

4.3.1 安装前检查 Pre-installation Check

打开前请检查包装。如果发现任何异常，不要打开包装，并与您的经销商联系。根据装箱单检查箱内各部件数量。如有零件丢失或损坏，请与您的经销商联系。

Check the PACK package before open it. If any abnormality is detected, do not open the Package and contact your distributor.

Check the quantity of all parts inside according to the package list. If there is any part missing or damaged, please contact your distributor.

4.3.1.1 检查GPHB-48100S零件清单 Check the list of GPHB-48100S



4.3.1.2 检查GPHB-48100S Module零件清单 Check the list of GPHB-48100S Module

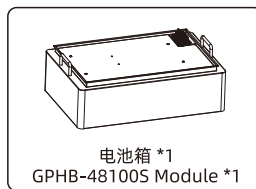

4.3.1.3 检查底座和墙架 Check the battery base and wall bracket

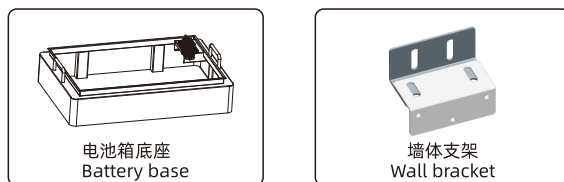



Notice

高压控制器(GPHB-48100S)和电池组(GPHB-48100S Module)是标准配件，请务必购买两者，一个电池系统只需要一个高压控制器(GPHB-48100S)，电池组(GPHB-48100S Module)你可以自由匹配的数量在2到8之间。

高压控制器(GPHB-48100S)到PCS的连接线需要另行购买。

如果要同一电池系统安装在两条线路上，则需要单独购买延长线连接。

只支持落地式安装方式。

The high voltage controller (GPHB-48100S) and the battery pack (GPHB-48100S Module) are standard accessories, please be sure to purchase both, a battery system only needs a high voltage controller (GPHB-48100S), battery pack (GPHB-48100S Module) You can freely match the number within 2 to 8 .

You need to separately purchase the connection cable from the high voltage controller (GPHB-48100S) to the PCS.

If you want to install the same battery system in two lines, you need to purchase a extension cable separately for connection.

Only floor standing installation is supported.

4.3.2 落地式安装 Floor Standing Installation

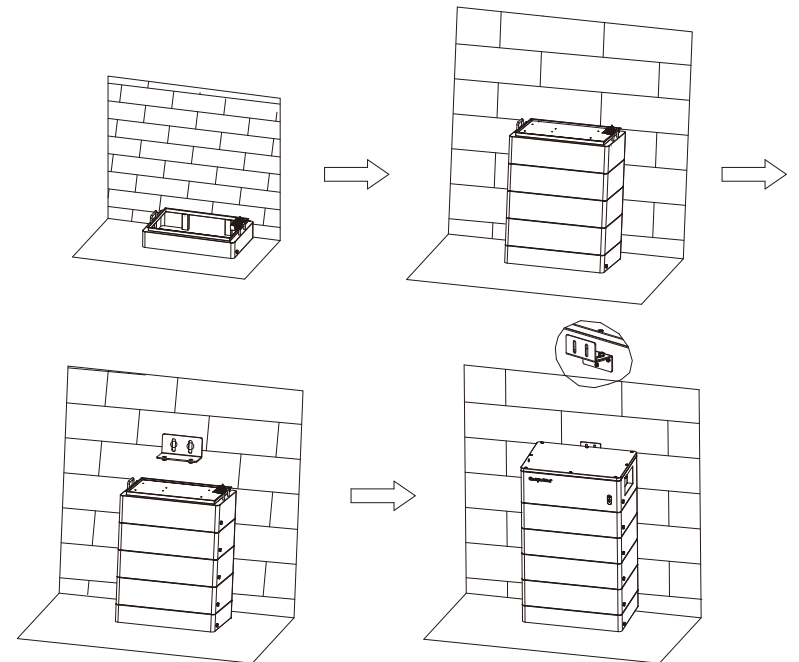

步骤1:将电池底座放置有待安装区域，用记号笔在安装孔位置上做记号。墙壁与电池之间的最小距离为300mm。

步骤2:选择直径为10mm的合金钻，在墙上钻一个至少60mm深的安装孔。将膨胀管插入孔内，拧紧螺钉以固定墙架。

步骤3:将电池堆叠在底座上。

步骤4:锁紧高压控制器与墙支架之间的安全螺钉，确保电池不会晃动。

Step 1: Place the battery base in the area to be installed, and mark the position of the installation hole with a marker. The minimum distance between the wall and the battery is 300mm.

Step 2: Select an alloy drill with a diameter of 10mm and drill a mounting hole at least 60mm deep in the wall. Insert the expansion pipe into the hole and screw in the screws to secure the wall bracket.

Step 3: Stack the battery on the base.

Step 4: Lock the safety screw between high voltage controller and wall bracket, and then make sure the battery will not shake.

4.4 电气连接 Electrical Connection



Notice

请佩戴防静电腕带、绝缘手套和护目镜。

Do not forget wear ESD wrist strap and insulated gloves, safety goggles.

4.4.1 RJ45通讯端口针脚定义 Definition of RJ45 communication port pin

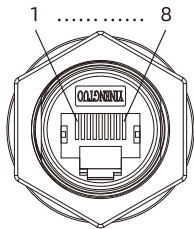

序号 No.	PCS端口 PCS port	PC端口 PC port
1	RS485_B	/
2	RS485_A	/
3	GND	RS232_TXD
4	CAN_H	/
5	CAN_L	GND
6	GND	RS232_RXD
7	RS485_A	/
8	RS485_B	/

4.4.2 系统连线图 System connection diagram



Notice

连接电源线时，必须用同一颜色的端子连接，否则可能出现短路等危险。

高压控制器已安装直流空开。如果需要在电池系统和PCS之间安装直流空开，请自行购买，规格如下：

a. 电压: 800Vdc/1000Vdc

b. 电流: 80A

When connecting the power line, it must be the same color terminal to connect, otherwise there may be dangers such as short circuit.

DC circuit breaker has been installed in the high voltage controller. If you want to install a DC circuit breaker between the battery system and the PCS, you need to purchase it yourself according to the following specifications:

a. Voltage: 800Vdc/1000Vdc

b. Current: 80A

注意：

电池不允许在运行状态下安装。安装前请关闭系统电源。

为保证系统安全，请不要忘记安装接地线。

连接PCS的线缆可以从高斯宝购买。

Note:

The battery is not allowed to be installed in the running state. Turn off the system power before installation.

To ensure system security, do not forget to install ground wire.

The cable connecting PCS can be purchased from Gospower.

4.4.2.1 连接线缆 Wiring connection

步骤1:将电源线插入相应的端口，然后有“咔”的声音表示连接成功。

步骤2:将通信线缆插入“PCS”端口，顺时针拧紧通信端子。(“PCS”端口连接PCS。)

步骤3:用6mm*2的接地线通过接地端子连接到地面。

Step 1: Insert the power cable into the corresponding port, then there is click sound indicating the connection is ok.

Step 2: Insert the communication cable into the "PCS" port, and then tighten the communication terminal clockwise. ("PCS" port connects to the PCS.)



Step 3: Connect to the ground using a 6mm*2 grounding wire through the grounding terminal

 Notice	<p>连接电源线时请注意接头颜色。只有相同颜色的连接器才能连接在一起。</p> <p>为保证系统安全，请不要忘记安装接地线。</p> <p>Please pay attention to the connector color when connection the power line. Only the same color of the connector could be connected together.</p> <p>To ensure system security, do not forget to install ground wire.</p>
---	---

5、开关电池系统 Power on/off Battery system

 Notice	<p>电池的安装和使用需要由专业技术人员操作。不要接触任何有电位差的部位。</p> <p>电池上应悬挂禁止标志：“非专业人员，请勿触摸”。</p> <p>如果启动阶段出现异常，请立即将系统下电。问题确认后，重新进行操作。</p> <p>检查电池系统前，请确保逆变器处于关闭状态。</p> <p>The installation and use of batteries need to be operated by professional technicians.</p> <p>Do not contact any positions with potential difference. Prohibition sign should be hung on the battery: " Non - professionals, do not touch ".</p> <p>If any abnormalities occur during the startup phase, power off the system immediately. After problem confirmed, proceed again.</p> <p>Make sure the inverter is turned off before checking the battery system.</p>
---	---

5.1 电池系统开机 Power on Battery system

 WARNING	<p>在打开电池之前，请检查电缆是否连接正确。</p> <p>Before turning on the battery, please check if the cable is properly connected.</p>
 Notice	<p>在某些情况下（比如欠压超过30分钟或静置超过3天）电池系统会主动断开断路器，但是POWER键不会弹起，在再次上电前应使POWER键处于弹起状态</p> <p>In some cases (such as under voltage for more than 30 minutes or rest for more than 3 days) the battery system will actively disconnect the circuit breaker, but the POWER button will not spring, and the POWER button should be off before powering on again.</p>

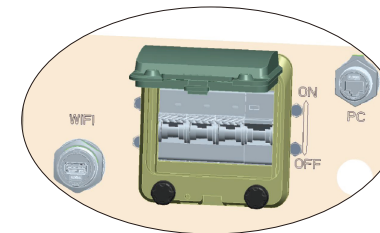

开机流程 Power on Procedures		
步骤 Setp	程序 Procedures	动作标准 Acceptation criteria
1	连接电池和PCS Connect the battery and PCS	确保线束连接良好 Make sure the wiring harnesses are well connected
2	闭合电池系统断路器 Close the breaker of the battery system	确保断路器处于ON状态 Make sure the breaker is ON
3	按下电源按钮。观察面板上的LED指示。 Press down POWER button. Observe the LED indication on status.	1. 如果RUN/ALM和SOC灯正常点亮则表示系统上电成功。 2. 如果RUN/ALM指示灯变为红色，则说明有故障，应在重新上电前解决。 1. If both RUN/ALM and SOC lights turn on normally, system is powered on successfully. 2. If RUN/ALM light turns red, there is a failure and should solve it before power on again.

5.2 电池系统关机 Power off Battery system

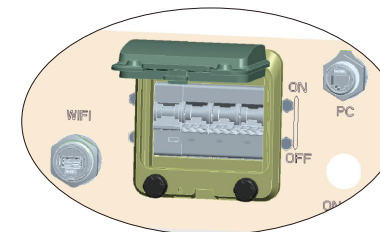

关机流程 Power off Procedures		
步骤 Setp	程序 Procedures	动作标准 Acceptation criteria
1	按下电源按钮。 Press down POWER button. Observe the LED indication on status.	确保电源按钮指示灯熄灭。 Make sure the POWER button LED is off.
2	断开电池系统断路器 Disconnect the breaker of the battery system	确保断路器处于OFF状态 Make sure the breaker is OFF

6、维护指南 Maintenance Guidelines

6.1 准备工作 Preparation

维护前，请确保电池系统已断电，直流空开已关闭。

Before maintenance, please make sure that the battery system is powered off and the DC circuit breaker is off.

6.2 更换电池组或高压控制器 Battery pack or high voltage controller replacement

戴上安全手套。

根据第5章规定的程序关闭电池系统电源。

断开电池系统的电源线和通信线路。

拆卸高压控制器背面与墙架之间的的安全螺钉。抬起电池组或高压控制器。

按照维修规程将电池包或高压控制器装入包装箱，并将电池包或高压控制器运到指定的维修地点。

根据第4章规定的程序安装新的电池组或高压控制器。

Wear safety gloves.

Power off the battery system based on procedure specified in Section 5.

Disconnect power lines and communication lines of the battery system.

Uninstall the safety screws between the back of high voltage controller and the wall bracket. Lift up the battery pack or high voltage controller.

Put the battery pack or high voltage controller into the packing box according to the repair procedure and transport the battery pack or high voltage controller to the designated repair site.

Install new battery pack or high voltage controller based on procedure specified in Section 4.

 Notice	<p>在更换电池之前，请使用充电器将新电池和现有电池充满(SOC 100%)。</p> <p>如果电池不使用，建议每3个月对电池进行一次充放电，以激活化学特性，最长间隔不超过6个月。</p> <p>Before replacing the battery, use the charger to charge the new battery and the existing battery to full (SOC 100%).</p> <p>If the battery is not used, it is recommended to charge and discharge the battery every 3 months to activate the chemical characteristics, and the maximum interval shall not exceed 6 months.</p>
---	---

6.3 系统故障信息及建议 System fault information and suggestions

故障指示 Error indication	故障描述 Error description	故障原因 Error cause	建议采取的措施 Suggested actions
RUN/ALM Light is red	输出短路 Output short circuit	电池系统外部短路 External short circuit of battery system	存在安全风险，用户应停止使用电池。 There is safety risk and user should stop using battery. 用户应联系安装人员维修PCS和电池。 User should contact installer to repair PCS and battery.
	传感器失效 Sensor failure	BMS 传感器失效 BMS sensor failure	存在安全风险，用户应停止使用电池。 There is safety risk and user should stop using battery. 用户应联系安装人员维修电池。 User should contact installer to repair battery.
	电芯失效 Cell failure	电芯损坏或寿命结束 The battery is damaged or expired	存在安全风险，用户应停止使用电池。 There is safety risk and user should stop using battery. 用户应联系安装人员维修电池。 User should contact installer to repair battery.

欠压保护 Discharge under voltage protection	电芯单体电压低于欠压保护阈值。 Single cell voltage below the threshold for under-voltage protection.	有过放电的风险。用户应停止放电并进行充电。 There is over discharge risk. User should stop discharging and arrange re-charging.
过压保护 Charge overvoltage protection	电芯单体电压超过保护阈值。 Single cell voltage exceeding threshold for protection threshold.	1. 没有安全威胁; 2. 用户应停止充电。请等待电池系统自动修复故障。 1. There is no safety threat; 2. User should stop charging. Wait for the battery system to automatically resolve the fault.
高温保护 High temperature protection	温度超过保护值。 The temperature exceeds the protection value.	有安全风险, 请立即停止使用电池, 等待电池温度下降, 故障自动解决。 It is dangerous, please stop using the battery immediately, wait for the battery temperature to drop, the fault will be automatically resolved.
低温保护 Low temperature protection	温度低于保护值。 The temperature is below the protection value.	无安全隐患, 待温度升高后, 故障自动解决。 No safety risk, wait for the temperature to rise, the fault will be automatically resolved.

7、技术规格 Technical Specifications

7.1 系统数据 System Data

系统型号 System Model	GPHB-48100S-2	GPHB-48100S-3	GPHB-48100S-4	GPHB-48100S-5
标称电量 Nominal Energy	10.24kWh	15.36kWh	20.48kWh	25.6kWh
额定功率 Rated Power	5.12kWh	7.68kWh	10.24kWh	12.8kWh
最大功率 Max Power	7.68kWh	11.52kWh	15.36kWh	19.2kWh
标称容量 Rated Capacity	100Ah (@25°C)			
标称电压 Nominal Voltage	102.4V	153.6V	204.8V	256V
电压范围 Voltage Range	86.4V~116.8V	129.6V~175.2V	172.8V~233.6V	216V~292V
尺寸 Dimensions (mm)	604x390x662	604x390x825.5	604x390x989	604x390x1152.5
重量 Weight (kg)	119.3kg	165.55kg	211.8kg	258.05kg
额定电流 Rated Current	50A			
最大电流 Max Current	75A 10s			
放电深度 DOD	90%			
工作温度 (充电) Operating Ambient Temperature (Charge)	0°C~45°C			
工作温度 (放电) Operating Ambient Temperature (Discharge)	-20°C~45°C			
工作湿度 Humidity	5%~95%			
储存温度 Storage Temperature	0°C~35°C (> 1 month) -20°C~45°C (≤1 month)			
散热方式 Cooling method	自然冷却 Natural cooling			

安装方式 Installation	落地式 floor stacking installation
海拔高度 Altitude	≤2000m
通讯方式 Communication Method	RS485/CAN (to PCS), RS232 (to PC)
产品认证 Product Certification	IEC62619
运输认证 Transport Certification	UN38.3
IP防护等级 Ingress Protection	IP65
环境安全认证 Environment Certification	RoHS
电池类型 Battery Type	磷酸铁锂电池 LiFePO4 Battery
质保期 Warranty	10年 10 years

系统型号 System Model	GPHB-48100S-6	GPHB-48100S-7	GPHB-48100S-8
标称电量 Nominal Energy	30.72kWh	35.84kWh	40.96kWh
额定功率 Rated Power	15.36kWh	17.92kWh	20.48kWh
最大功率 Max Power	23.04kWh	26.88kWh	30.72kWh
标称容量 Rated Capacity	100Ah		
标称电压 Nominal Voltage	307.2V	358.4V	409.6V
电压范围 Voltage Range	259.2V~350.4V	302.4V~408.8V	345.6V~467.2V
尺寸 Dimensions (mm)	604x390x1316	604x390x1479.5	604x390x1643
重量 Weight (kg)	304.3kg	350.55kg	396.8kg

额定电流 Rated Current	50A
最大电流 Max Current	75A 10s
放电深度 DOD	90%
工作温度 (充电) Operating Ambient Temperature (Charge)	0°C~45°C
工作温度 (放电) Operating Ambient Temperature (Discharge)	-20°C~45°C
工作湿度 Humidity	5%~95%
储存温度 Storage Temperature	0°C~35°C (> 1 month) -20°C~45°C (≤1 month)
散热方式 Cooling method	自然冷却 Natural cooling
安装方式 Installation	落地式 floor stacking installation
海拔高度 Altitude	≤2000m
通讯方式 Communication Method	RS485/CAN (to PCS), RS232 (to PC)
产品认证 Product Certification	IEC62619
运输认证 Transport Certification	UN38.3
IP防护等级 Ingress Protection	IP65
环境安全认证 Environment Certification	RoHS
电池类型 Battery Type	磷酸铁锂电池 LiFePO4 Battery
质保期 Warranty	10年 10 years

 Notice	<p>当温度低于0°C时，性能将受到限制。 The performance will be limited when the temperature is below 0°C.</p>
---	--

7.2 高压控制器 High voltage controller

项目 Item	规格 Specification
型号 Model	GPHB-48100S
输入/输出电压范围 Input/Output Voltage Range	85V~750V
额定电流 Rated Current	50A
工作温度 Operating Ambient Temperature	-20°C~45°C
IP防护等级 Ingress Protection	IP65
质保期 Warranty	10年 10 years
通讯方式 Communication Method	RS485/CAN (to PCS), RS232 (to PC)
尺寸 Dimensions (mm)	604x390x230mm
重量 Weight (kg)	20.8kg
环境安全认证 Environment Certification	RoHS

7.3 电池组 Battery pack

项目 Item	规格 Specification
型号 Model	GPHB-48100S Module
标称能量/容量 Nominal Energy/Capacity	5.12kWh/100Ah
标称电压 Rated Voltage	51.2V
电压范围 Voltage Range	43.2V~58.4V
额定电流 Rated Current	50A
工作温度 (充电) Operating Ambient Temperature (Charge)	0°C~45°C

工作温度 (放电) Operating Ambient Temperature (Discharge)	-20°C~45°C
存储温度 Storage Temperature	0°C~35°C (> 1 month) -20°C~45°C (≤1 month)
散热方式 Cooling Method	自然冷却 Natural cooling
质保期 Warranty	10年 10 years
尺寸 Dimensions (mm)	604x390x226.7mm
重量 Weight (kg)	46.25kg
安全认证 Safety Certification	IEC62619
运输安全认证 Transport Certification	UN38.3
环境安全认证 Environment Certification	RoHS

附录 Appendix

LED显示控制机制

LED indication Control Mechanism

LED灯状态定义 LED light definition							
状态 Status	项目 Item	SOC指示 SOC indication				运行/告警 RUN/ALM	备注 Remark
		LED1	LED2	LED3	LED4	LDE5	
Charging	100%-76%	★	★	★	●	★	● 为流水灯 is flow water light
	75%-51%	★	★	●	●	★	
	26%-50%	★	●	●	●	★	
	0%-25%	●	●	●	●	★	
Discharging or Idle	100%-76%	★	★	★	★	★	
	75%-51%	★	★	★	●	★	
	26%-50%	★	★	●	●	★	
	0%-25%	★	●	●	●	★	
系统更新 System updating	固件下载 Firmware downloading					★(t=0.6S)	RUN/ALM 灯闪烁绿色 RUN/ALM light flashing green
保护 Protection	电芯过压保护 Cell charge overvoltage protection	指示当前剩余容量 indicates current remaining capacity				★(t=0.6S)	RUN/ALM 灯闪烁红色 RUN/ALM light flashing red
	电芯欠压保护 Cell discharge undervoltage protection					★(t=0.6S)	
	电芯高温保护 Cell high temperature protection					★(t=0.6S)	

	电芯低温保护 Cell low temperature protection		★(t=0.6S)	
	环境高温保护 High ambient temperature protection		★(t=0.6S)	
	环境低温保护 Low ambient temperature protection		★(t=0.6S)	
	电芯压差过大 保护 Cell large voltage difference protection		★(t=0.6S)	
系统错误 System Failure	输出短路 Output short circuit		★(t=0.6S)	RUN/ALM light on red RUN/ALM 灯亮红灯
	传感器失效 Sensor failure		★	
	绝缘不良 Insulation failure		★	
	电芯失效 Cell failure		★	